

DewEZE

710029	Bracket Assy. (Inc. items 4-7,31)	Clutch Pump Kit	700013
710463	Bracket Bolt Pkg. (Inc. items 10-13,17-19,21-23,28-30)	Make	Chevy
710452	Pulley Bolt Pkg. (Inc. items 14,15,21,23,26,27)	Engine Size	454
700182	Fan Spacer Bolt Pkg. (Inc. items 16,24,25)	Fuel	Gas
		Year	1985-87
		Options	
		Revised	A 5-17-94

ITEM	PART #	DESCRIPTION
1.	*	Pump
2.	740037	Clutch, Standard
	740038	Clutch, Heavy Duty
3.	710353	Footmount
4.	710182	Front Bracket
5.	710183	Pump Bracket
6.	710195	Rear Bracket
7.	710187	Take-up Bracket
8.	740013	Crankshaft Pulley
9.	700172	Fan Spacer
10.	110542	3/8" X 5 1/2" NC Bolt
11.	110543	7/16" X 7" NC Bolt
12.	110519	3/8" X 6 1/2" NC Bolt
13.	110435	3/8" X 1 1/2" NC Bolt
14.	110495	3/8" X 3 3/4" NC Bolt
15.	110132	1/2" X 3 3/4" NF Bolt
16.	110056	5/16" X 2 3/4" Stud
17.	710202	Spacer, 4.280"
18.	710198	Spacer, 5.500"
19.	710201	Spacer, 3.025"
20.	740055	V-Belts, Gates A59
21.	110676	3/8" Flat Washer
22.	110612	3/8" NC Nut
23.	110672	3/8" Lock Washer
24.	110608	5/16" NC Nut
25.	110674	5/16" Lock Washer
26.	110666	1/2" Lock Washer
27.	110658	1/2" Flat Washer
28.	110425	3/8" X 1 1/4" NC Bolt
29.	710200	Spacer, 0.700"
30.	110404	3/8" X 1 3/4" NC Bolt
31.	710196	Bracket

* See Master List for Pump Part No.

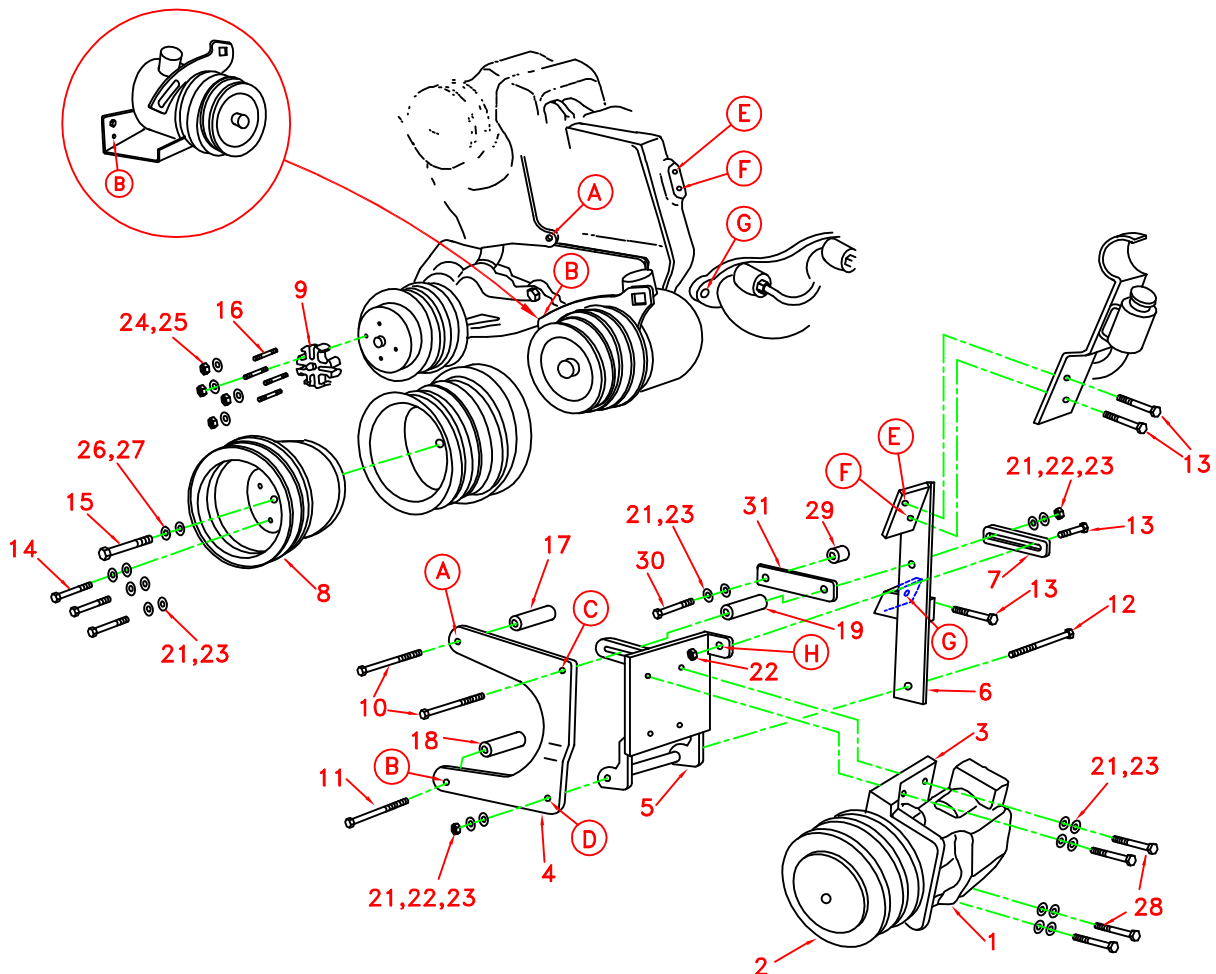

(A) Denotes bolt holes in engine to locate corresponding holes in Pump Brkt.

Chevy - 454
1985-87
Clutch Pump Kit #700013

INSTALLATION INSTRUCTIONS

NOTE: Suction hose to pump must be a wire braid hose; minimum 1" I.D. for 7 & 9 gpm pumps; 1 1/2" I.D. for 12 & 17 gpm pumps. Installations with smaller suction hoses will void the pump warranty.

1. Remove fan and shroud.
2. Loosen all OEM fan belts.
3. Loosen and remove OEM crankshaft pulley bolts.

NOTE: The 1/4" thick, flat washer under center bolt will not be used when reinstalling pulley.

4. Install the DewEze Aluminum crankshaft pulley (8) using three 3/8" X 3 3/4" (14) and one 1/2" X 3 3/4" NF (15) Bolts.
5. Remove OEM stud bolts from water pump pulley.
6. Install one DewEze Stud Bolt (16) for the Fan Extension (9) into the water pump.

NOTE: Fine thread end of bolt goes into water pump.

- A. Lower fan assembly into position. Mark stud bolt to be cut off to allow fan assembly to go between radiator and end of stud bolt.
 - B. Cut all four stud bolts to marked length.
 - C. Install four stud bolts into water pump.
 - D. Slide 1" Fan Spacer (9) over stud bolts. Place lock washer and nut on two stud bolts and tighten. This will hold fan spacer in place during engine check run.
 - E. Tighten OEM belts.
7. Remove first bolt in exhaust manifold on driver's side, Hole G.
 8. Install Bracket (6).

NOTE: There are two hose lines on back side of Power Steering Pump. Loosen the clamps on these lines and slide the screw adjustment to back side of lines. Retighten clamps. The steel line must be bent down, away from the DewEze Bracket, but kept off of frame.

- A. If Stainless Steel Exhaust Manifold use one 3/8" flat washer between bracket and manifold, Hole G.
- B. If Cast Iron Exhaust Manifold use no washers at Hole G.
- C. Use bracket (31), spacers (17), (18), (19), and bolt (30).

Do not tighten bolts yet.

9. Remove OEM Bolts at Holes A and B. Install Bracket (4) using 3/8" X 5.5" Bolts (10).
 - A. Use 4.280" spacer (17) at Hole A.

B. Install 7/16" X 7" Bolt (11) and 5.5" spacer (18) at Hole B.

10. Install Clutch (2) onto Pump (1). Install Clutch and Pump Assembly loosely on bracket (5) using four bolts (28). Lower this Assembly between brackets (4) and (6). Install 3/8" X 6.5" Bolt (12) from front side, with nut, lock washer and flat washer on back side.
11. Install Matched set of V-Belts (Gates A59) by tipping pump assembly slightly forward.
12. Install 3/8" X 5 1/2" Bolt (10) at Hole C, with 3.025" spacer (19), and Take-Up Bracket (7) with nut, lock washer, and flat washer on back side.
13. Tighten all bracket mounting bolts.
14. Install 3/8" X 1 1/2" Bolt (13) and Nut (22) at Hole H.
15. Align the Clutch Pulley and the Crankshaft Pulley by placing a straight edge across the front surface of both pulleys. Tighten Bolts.
16. Tighten belts by loosening the pivot Bolt (12) at Hole D, Bolt (10) at Hole C, and Bolt (13) at Hole H. Pry pump and pump bracket away from engine, then tighten bolts.
17. Start and run engine, checking for vibration or alignment problems.
18. Trim off the Fan Shroud as needed for clearance of Crankshaft Pulley, Belts, and Fan Extension.
19. Install Fan and Fan Shroud.
20. Run engine, checking clearance, vibration, and alignments.