

711384	Bracket Assy. (Inc. items 1, 2, 3, 15)		Kit No.	<b>700386</b>
711356	Bracket Bolt Pkg. (Inc. items 6, 8)		Make	Chevrolet/GMC
None	Pulley Bolt Pkg.		Engine	6.0L
711368	Idler Pulley Bolt Pkg. (Inc. items 7, 12, 16)		Fuel	Gas
711370	Idler Brkt. Bolt Pkg. (Inc. items 13, 14)		Year	2001
None	Fan Spacer Bolt Pkg.		Equipment	130A (H.D.) Alt.
			Revised	C 1-8-02

ITEM	PART #	DESCRIPTION		
1.	711399	Engine bracket	10.	OEM Bolt
2.	-----	-----	11.	110425 3/8-16 x 1 1/4 Bolt
3.	710936	Pump plate	12.	110676 3/8 Flat washer
4.	*	Pump, rear port	13.	110215 M10 x 120 x 1.5 Bolt
5.	740144	Clutch	14.	110181 M10 x 130 x 1.5 Bolt
6.	110465	3/8-16 x 1 1/4 Socket head bolt	15.	711365 Idler bracket
7.	110526	M10 x 40 x 1.5 Bolt	16.	711366 Idler bushing
8.	110217	M10 x 70 x 1.5 Bolt	17.	740294 Idler
9.	OEM	Bolt	18.	740336 Belt/Dayco 5061223

\* See master list for pump part no.

FIG. 1

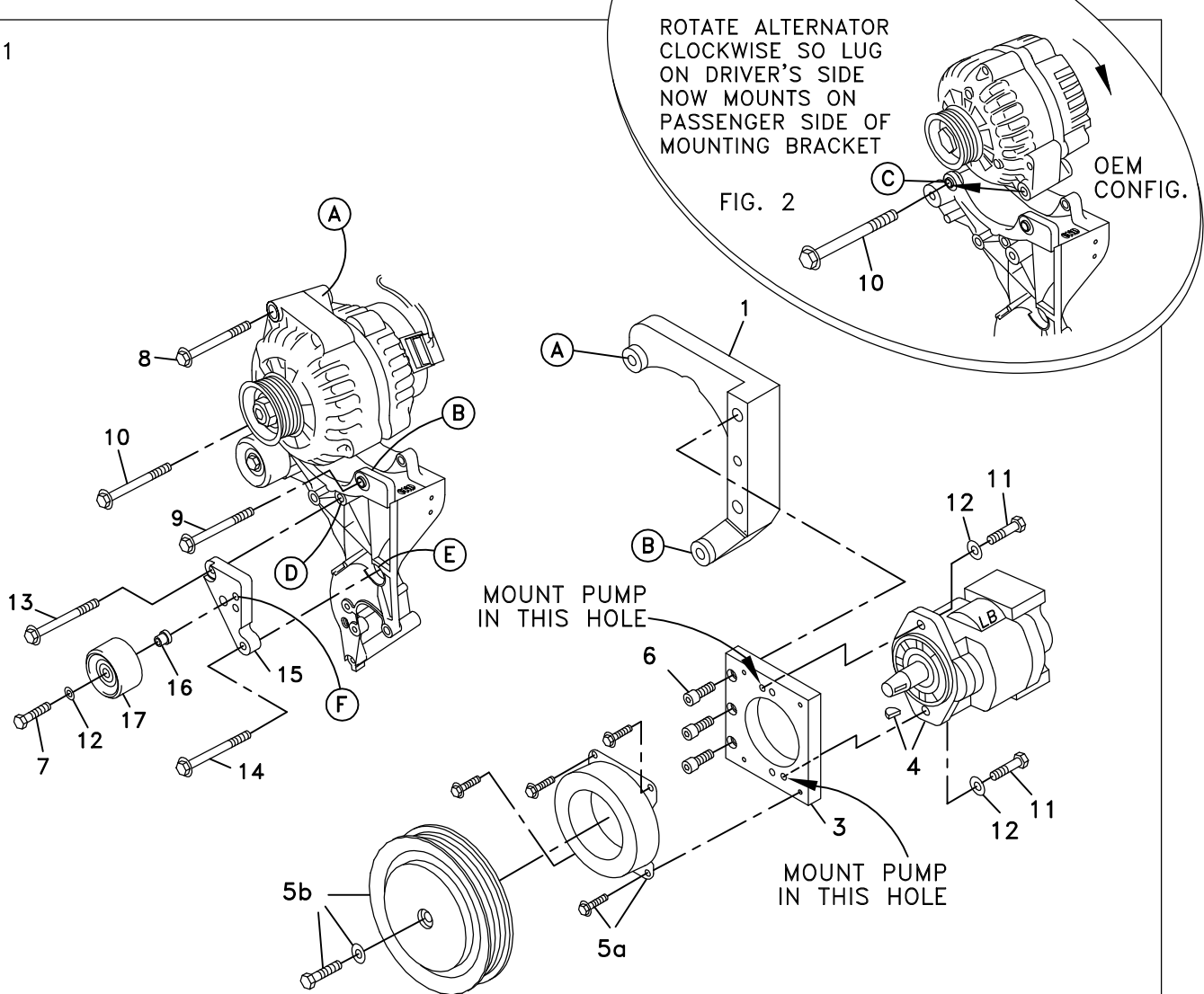
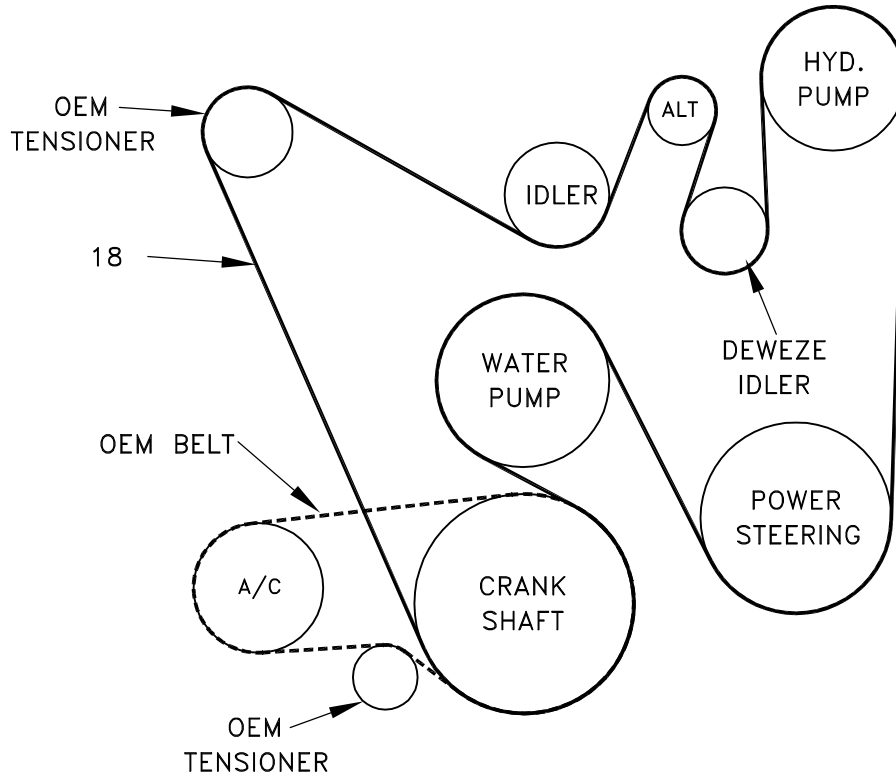

FIG. 3

BELT DIAGRAM



# DewEze

Clutch Pump Kit  
#700386  
Chevy 6.0L  
With 130A alt.  
and A/C  
'A' mount  
2001-

## I N S T A L L A T I O N I N S T R U C T I O N S

1. Disconnect the battery.
2. Unbolt the alternator. Rotate it clockwise so the alternator lug that was on the driver's side of the mounting bracket is now on the passenger side of the mounting bracket. See Fig. 2. Thread the OEM bolt (10) that was originally in that hole back into the same location to mount the alternator. Do not tighten it yet.
3. Attach the pump plate (3) to the engine bracket (1) with three 3/8 x 1 1/4 socket head bolts (6).
4. Bolt pump (4) onto pump plate (3) with two 3/8 x 1 1/4 bolts (11) and two 3/8 flat washers (12). Torque to 20 ft-lb. Attach coil (5a) with four 1/4 x 1/2 flange bolts supplied with clutch. Torque these to 6 ft-lb. Attach clutch pulley (5b) to pump shaft with 5/16NF x 1 1/4 bolt and heavy washer supplied with clutch. Torque to 14 ft-lb.
5. Insert the lower bracket between the lugs on the alternator bracket at location B with the OEM bolt (9) taken from this location. Insert the M10 x 70 bolt (8) into the top hole in the alternator and thread into the DewEze bracket at location A. Tighten these bolts and the OEM bolt at location C.
6. Remove OEM bolts at locations D and E and discard. Insert the idler bushing (16) into the back of the idler pulley (17). Insert the M10 x 40 bolt (7) through the 3/8 flat washer (12), through the front of the idler pulley with bushing and into the top threaded hole at location F in the idler bracket (15). Attach the idler bracket to the alternator bracket with the M10 x 120 bolt (13) at location D and the M10 x 130 bolt (14) at location E.
7. Install the belt (18).
8. Connect the battery.
9. Run the engine and check for any clearance or alignment problems. Adjust as needed.