

**Sterling w/Mercedes MBE900 :D, 2005, A Pump, Rear Port**

**Bolt Packages:**

Bracket	711694 (Inc. item 11, 12)
Idler	711695 (Inc. item 4, 13, 14)
Crank pulley	None
Tensioner	None

Bracket Assy.	711693 (Inc. items 1-3)
Issue Date	3-18-05
Revision Date	A 12-6-05

**Item Part No. Description**

1.	711689	Pump plate mount	13.	110559	M8 x 1.25 x 40 Bolt
2.	711690	Alternator bracket, upper	14.	110665	5/16 Flat washer
3.	711691	Alternator bracket, lower	15.	110425	3/8-16 x 1 1/4 Bolt
4.	711692	Idler bushing	16.	110676	3/8 Flat washer
5.	710936	Pump plate	17.	742030	Belt, Micro-v K080922
6.	740261	Idler			
7.	*	Pump			
8.	742009	Clutch			
9.	700278	Hose, crankcase ventilation			
10.	OEM	Tube			
11.	110487	M10 x 1.5 x 120 Bolt			
12.	110465	3/8-16 x 1 1/4 Socket head bolt			

\* See pump list for sizes and part numbers.

**FIG. 1**

**BELT DIAGRAM**

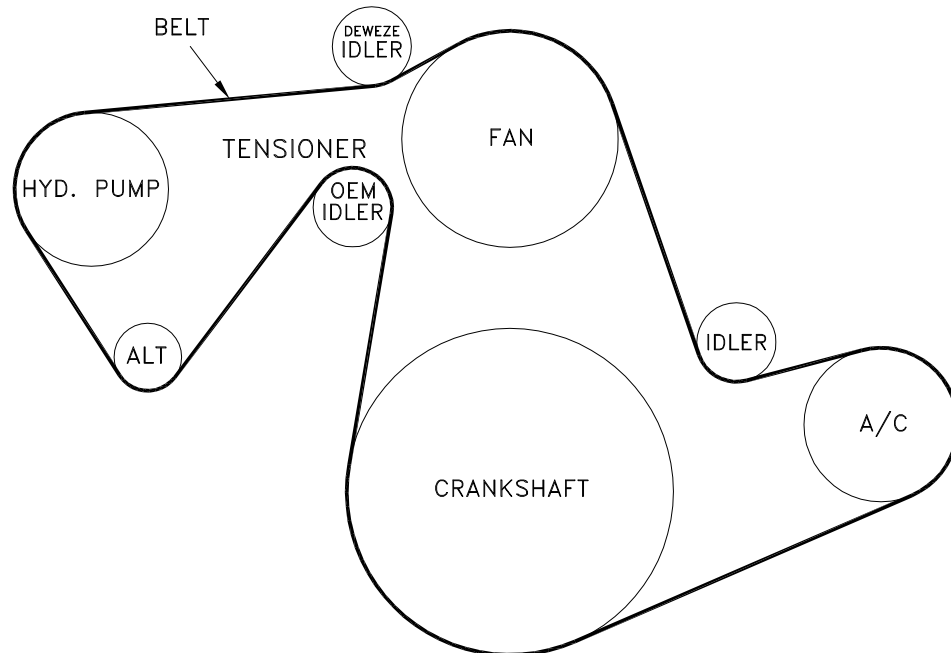

**FIG. 2**

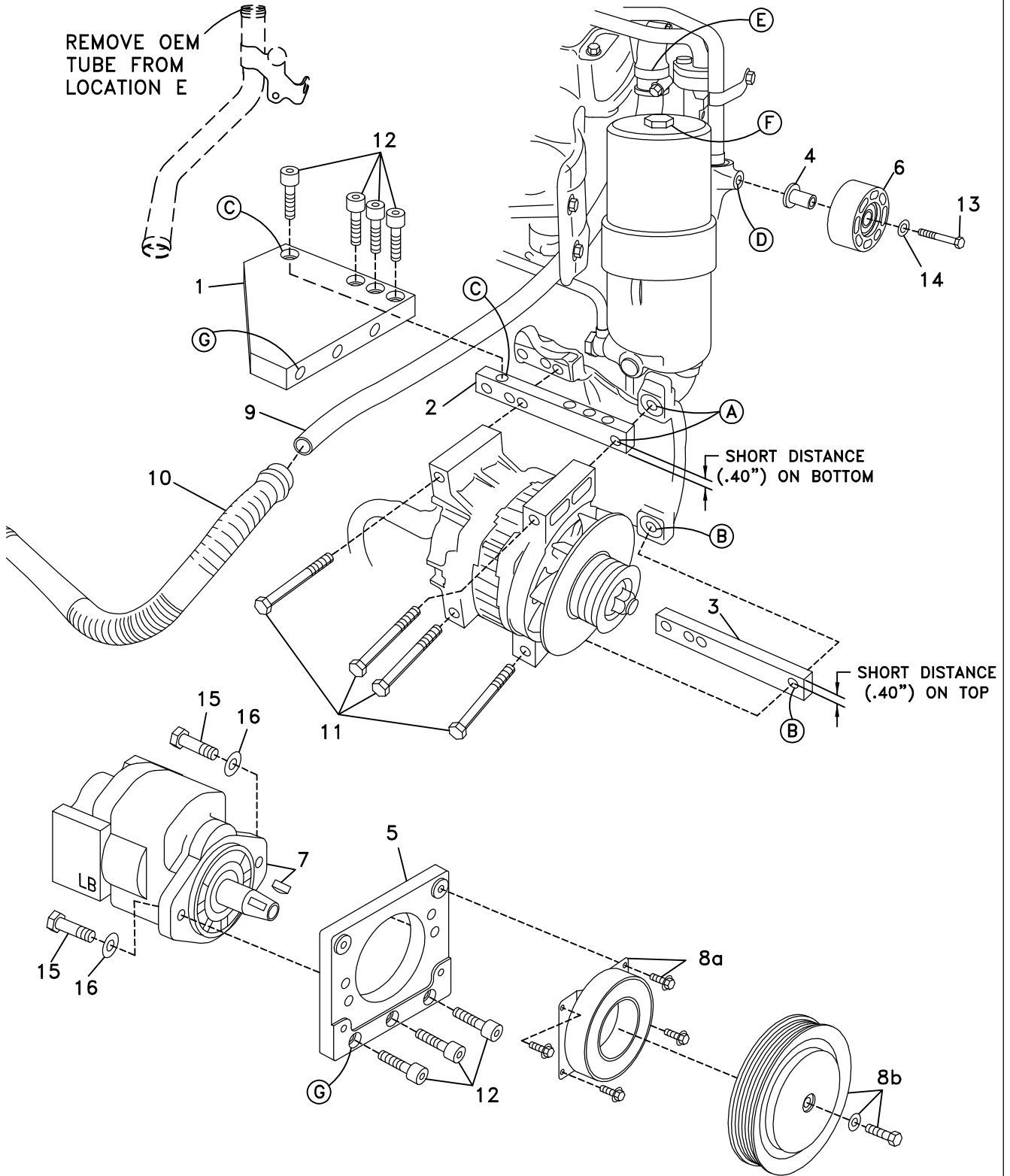

# DewEze

## Clutch Pump Kit

Clutch Pump Kit  
700440  
Sterling  
MBE 900  
'A' mount  
2005+

# INSTALLATION INSTRUCTIONS

---

1. Disconnect the battery.
2. Remove the passenger side inner fender. Remove the air cleaner and its support bracket.
3. Remove the top of the oil filter at Location F. Remove the crankcase ventilation tube from the rubber elbow in the side of the engine at Location E behind the filter. Detach this tube at its lower end from the metal flex tube (10). Save the clamps to use over.
4. Insert the flexible replacement tube (9) into the elbow at the top, fastening with the OEM clamp. Attach the lower end of this tube to the OEM metal tube with the OEM clamp. Replace the oil filter.
5. Remove the OEM belt.
6. Insert the idler bushing (4) into the idler (6) and attach it to the front of the engine on the other side of the oil filter at Location D with the M8 x 40 bolt (13) and the 5/16 flat washer (14).
7. Loosen the top two bolts that mount the alternator at Location A. Remove the bottom two alternator bolts At Location B. Slide the lower alternator bracket (3) between the alternator and its mounting bracket at Location B orienting it with the shorter hole to edge distance on top as shown in Fig. 2. Loosely thread two M10 x 120 bolts (11) into the bottom of the alternator. Remove the two upper OEM alternator bolts. Slide the upper alternator bracket (2) between the alternator and its mounting bracket at Location A orienting it with the shorter hole to edge distance on the bottom as shown with two M10 x 120 bolts (11).
8. Attach the horizontal mounting plate (1) to the upper alternator bracket (2) with four 3/8 x 1 1/4 socket head bolts (12).
9. Attach the pump (7) to the pump plate (5) with two 3/8 x 1 1/4 bolts (15) with two 3/8 flat washers (16). Attach the pump plate with pump to the horizontal bracket with three 3/8 x 1 1/4 socket head bolts (12).
10. Mount the clutch coil (8a) with the four 1/4 x 1/2 flange head bolts provided with the clutch. Mount the clutch pulley (8b) with the 5/16 x 1 1/4 bolt and heavy flat washer provided with the clutch.
11. Put the belt (17) in place on the pulleys.
12. Replace the air cleaner bracket and the air cleaner. Replace the inner fender.
13. Reconnect the battery.
14. Run the engine and check for any clearance or alignment problems. Adjust as needed.