

Chevrolet/GMC, 6.6L : D, 2006-2008, A Pump, Rear Port

Bolt Packages:

Bracket	711396	(Inc. item 3, 9, 12, 13)
Idler	711924	(Inc. item 4, 10, 15)
Crank pulley	None	
Tensioner	None	

Bracket Assy.	None
Issue Date	9-29-05
Revision Date	D 12-10-09

Item	Part No.	Description
1.	710099	Pump mount bracket
2.	-----	-----
3.	110188	M10 x 80 x 1.5 Socket head bolt
4.	711009	Idler bushing
5.	710936	Pump plate
6.	740151	Idler pulley
7.	*	Pump / Rear port
8.	742016	Clutch
9.	110217	M10 x 70 x 1.5 Bolt
10.	110210	M10 x 50 x 1.5 Bolt
11.	-----	-----
12.	110101	M10 x 1.5 Lock nut
13.	110395	3/8-16 x 1 Socket head bolt
14.	110425	3/8-16 x 1 1/4 Bolt
15.	110676	3/8 Flat washer
16.	740361	Belt, Poly Cog 1490K6

FIG. 1
BELT DIAGRAM

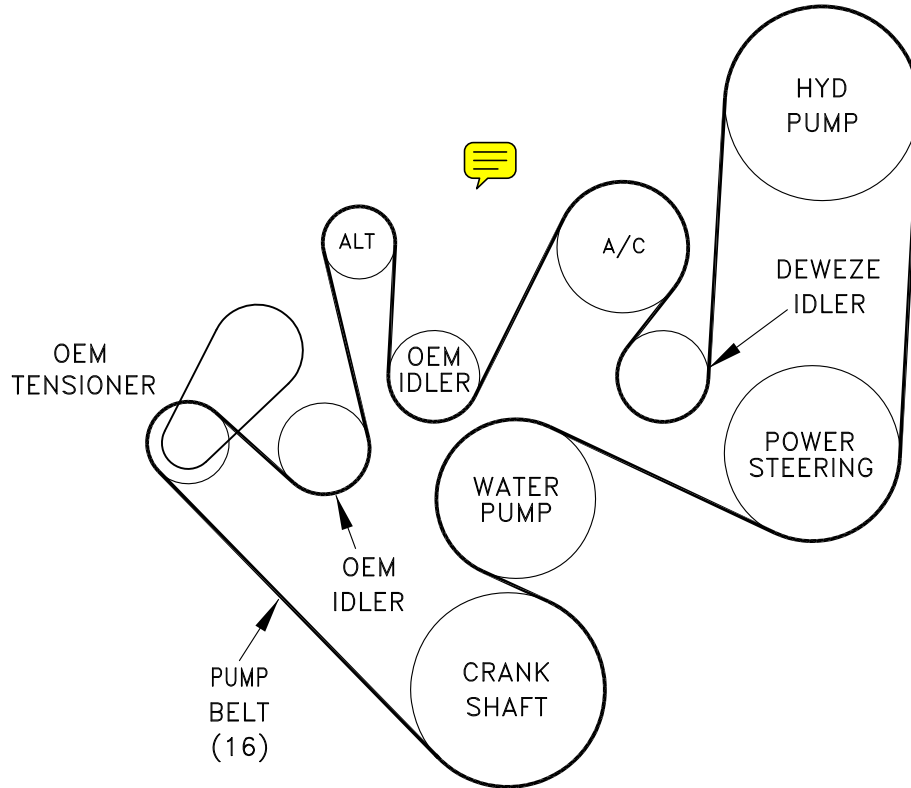
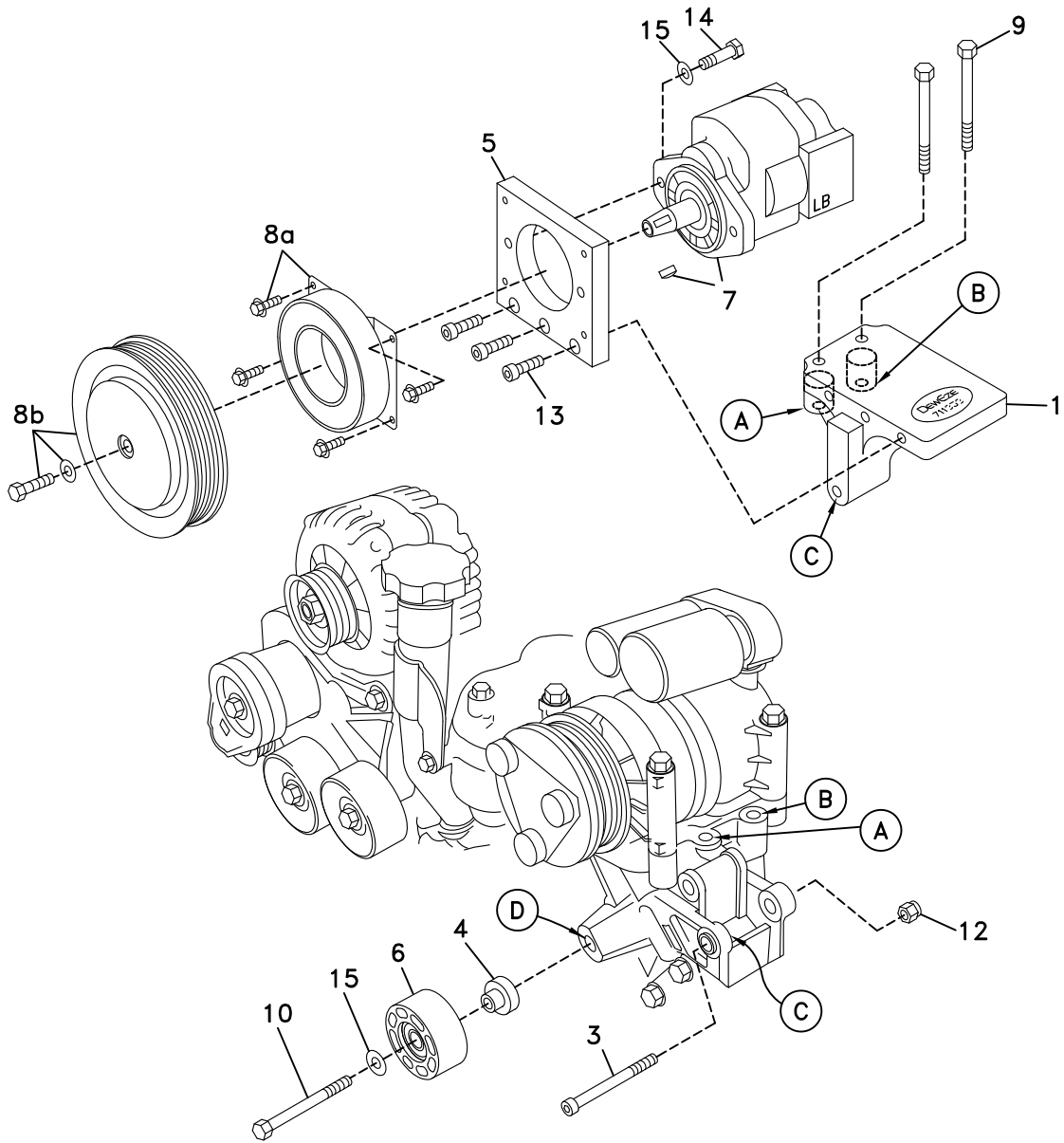

FIG. 2



DewEze

Clutch Pump Kit

#700445
Chevy 6.6L
with A/C
'A' mount
06-08

INSTALLATION INSTRUCTIONS

1. Disconnect the battery.
2. Remove the OEM belt.
3. Bolt the pump plate (5) to the base plate (1) with three 3/8 x 1 socket head bolts (13). Torque to 20 ft-lb.
4. Push the idler bushing (4) into the back (the side without the snap ring) of the idler pulley (6). Insert the M10 x 50 bolt (10) through a 3/8 flat washer (15), through the idler pulley and bushing and into the hole on the air conditioner bracket at location D.
5. Press bushing at Location C (secondary alternator mounting location) forward to allow clearance for pump mount bracket (1).
6. Insert the two M10 x 70 bolts (9) through the holes in the notched end of the base plate (1) and into the air conditioner mounting bracket at locations A and B. Thread the M10 x 80 socket head bolt (3) into the hole at Location C and through the bottom lug of the pump bracket. Tighten item 3 (M10 x 80mm socket head bolt) first to insure that bracket is aligned properly (25 ft-lbs). Tighten (9) bolts next and torque to 25 ft-lb. Secure with M10 nut (12).
7. Bolt pump (7) onto pump plate (5) with two 3/8 x 1 1/4 bolts (14) and two 3/8 flat washers (15). Torque to 20 ft-lb. Attach coil (8a) with four 1/4 x 1/2 flange bolts supplied with clutch. Torque these to 6 ft-lb. Attach clutch pulley (8b) to pump shaft with 5/16NF x 1 1/4 bolt and heavy washer supplied with clutch. Torque to 14 ft-lb.
8. Install the belt (16) as shown in the belt diagram (Fig. 1).
9. Connect the battery.
10. Run the engine and check for any clearance or alignment problems. Adjust as needed.