

DewezeClutch Pump Kit **700464****Ford, 6.8L:G, 2008+, F-350, A/C, AA Pump, Rear Port****Bolt Packages:**

Bracket	None
Idler pulley	711650 (Inc. 2, 8)
Pulley	None
Tensioner	None

Bracket Assy.	None	(Inc. items)
Issue Date	3-20-07	Revision Date NC 3-20-07

Item	Part No.	Description
------	----------	-------------

1.	711639	Pump bracket	16.	711822	Hose, crankcase vent
2.	711072	Idler bushing	17.	520098	Hose clamp
3.	*	Pump (rear port)	18.	OEM	Air tube
4.	740162	Clutch			
5.	740242	Idler pulley			
6.	OEM	Stud bolt			
7.	110775	M8 x 1.25 x 60 Bolt, low head			
8.	110479	M10 x 1.5 x 30 Bolt			
9.	110465	3/8 x 1 1/4 Socket head bolt			
10.	110271	3/8 Lock washer, .55 O.D. x .13 thick			
11.	110703	M8 Flat washer			
12.	OEM	Idler pulley			
13.	OEM	Nut			
14.	OEM	Wire			
15.	740357	Belt, Gates 6K126.68			

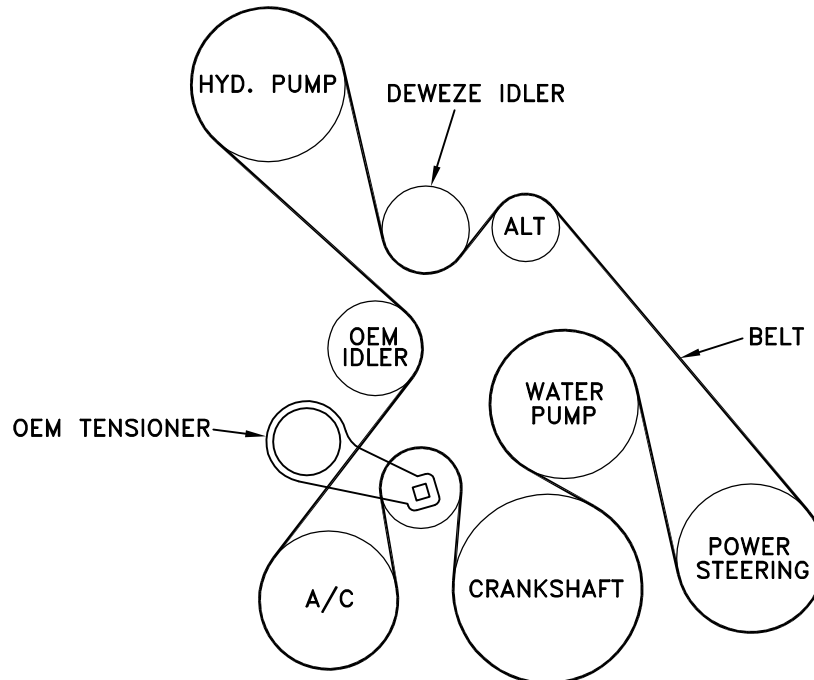
FIG. 1**BELT DIAGRAM**

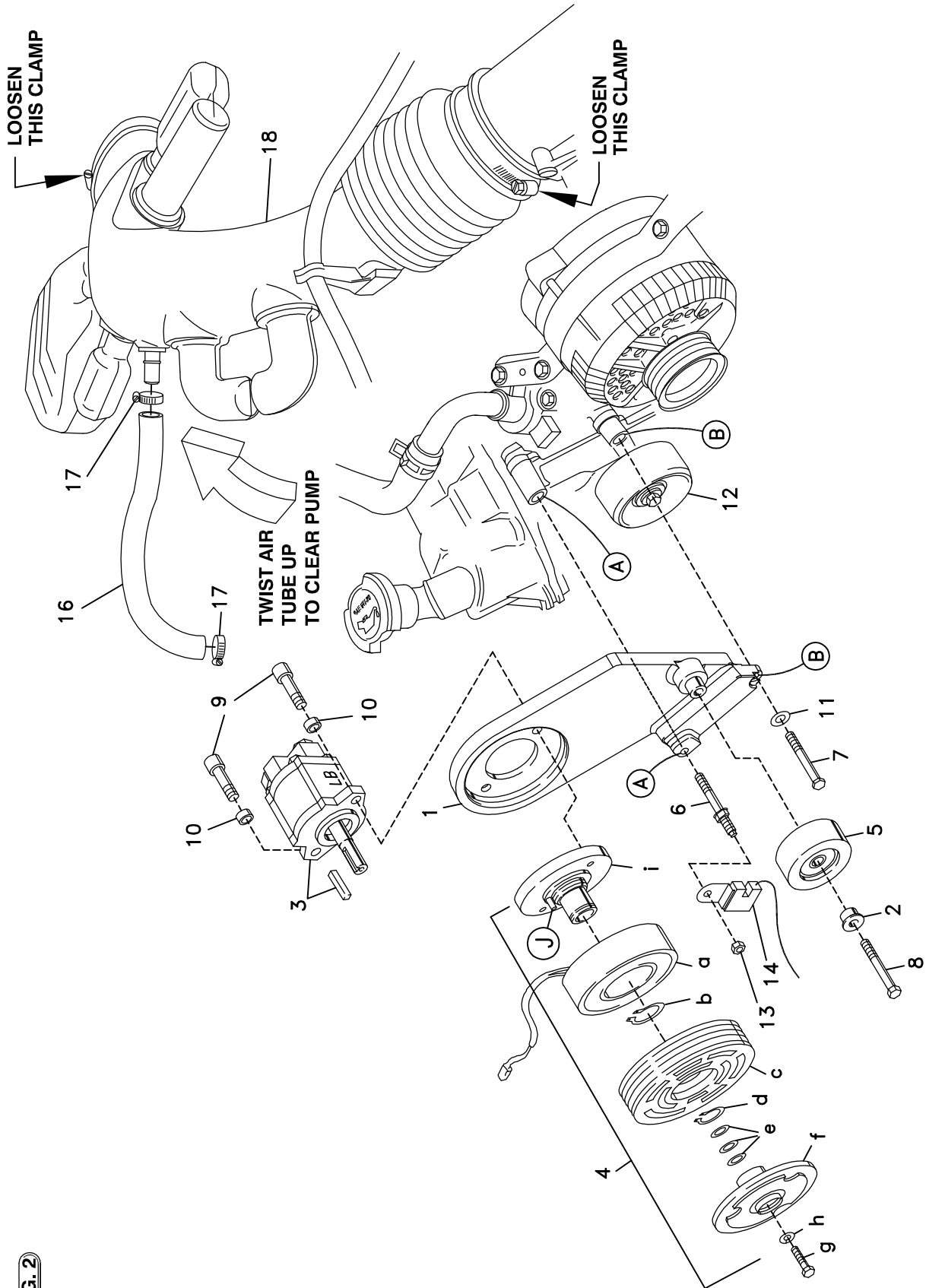

FIG. 2

DewEze Clutch Pump Kit 700464

Ford 6.8L, with A/C, AA, 2008+

INSTALLATION INSTRUCTIONS

1. The installation of this kit requires trained decision-making concerning clearances, tying components together, rerouting, or relocating OEM components, etc. It is impossible to describe all of the clearance and vibration points, etc. in the installation instructions. Therefore, the technician must exercise professional judgment to achieve the best quality installation.
2. Disconnect the battery.
3. Remove the OEM belt.
4. Remove the OEM crankcase vent hose. Replace it with the DewEze hose (16) with two hose clamps (17).
5. Remove OEM idler pulley (12) to gain access to mounting bolt at location B. Keep the pulley and bolt.
6. Remove nut (13) holding wire at location A. Remove stud bolt (6) at location A. Remove OEM bolt at location B.
7. Hold pump (3) onto back of bracket (1) and clutch hub (4i) onto front of bracket, making sure anti-rotation pin (D) on front of hub is on top. Place two 3/8 x 1 1/4 socket head bolts (9) and 3/8 high collar lock washers (10) through pump, through mounting plate and thread into hub. Torque to 20 lb-ft.
8. Slide coil (4a) over hub, aligning hole in the back plate of coil with the anti-rotation pin (D) in the hub. The wires from the coil should be on the same side as the pin (D). Install large snap ring (4b) to hold coil in place.
NOTE: THE BEVEL ON BOTH SNAP RINGS MUST FACE AWAY FROM THE PUMP. REFER TO INSTRUCTION SHEET FOR THE CLUTCH FOR CORRECT INSTALLATION OF SNAP RINGS.
9. Slide clutch pulley (4c) onto hub. Install small snap ring (4d) to hold pulley in place.
10. Place the key (3) onto the pump shaft. Slide the hub/armature (4f) onto the pump shaft aligning the keyways.
11. Thread bolt (4g) and lock washer (4h) into pump shaft. Torque to value in clutch instruction sheet.
12. Install the fittings on the pump.
13. Insert the idler bushing (2) into the idler pulley (5) and attach the other side to the boss on the front of the pump mount bracket (1) at Location C with the M10 x 30 shoulder bolt (8). Torque to 19-25 ft-lb.
14. See Fig. 3. Disconnect the wiring from the alternator, pull it from the attachment points on the valve cover and push it back on top of the valve cover. Make sure the alternator wiring will not be pinched between the engine and the pump bracket when it is installed.
15. Loosen the clamps at the end of the large plastic air tube (18). Twist the tube up so it clears the pump. Tighten the two clamps.
16. Attach the pump mount bracket (1) to the engine with the OEM stud bolt (6) at Location A and the M8 x 60 bolt at Location B. Torque these bolts to 19-25 ft-lb.
17. Replace the wire (14) on the stud bolt (9) rotating it 180 degrees from the OEM position so it points away from the pump bracket so it is not in the belt line. See Fig. 4. Reconnect wires to the alternator.
18. Reinstall OEM idler (12) using the OEM bolt in its original location. Torque to 19-25 ft-lb.
19. Install the serpentine pump drive belt (15) per diagram.
20. Connect the battery.
21. Run the engine and check for any clearance or alignment problems. Adjust as needed.

NOTE: SET THE AIR GAP BETWEEN THE HUB/ARMATURE AND THE PULLEY USING SHIMS (4e) ACCORDING TO INSTRUCTION SHEET FOR CLUTCH.

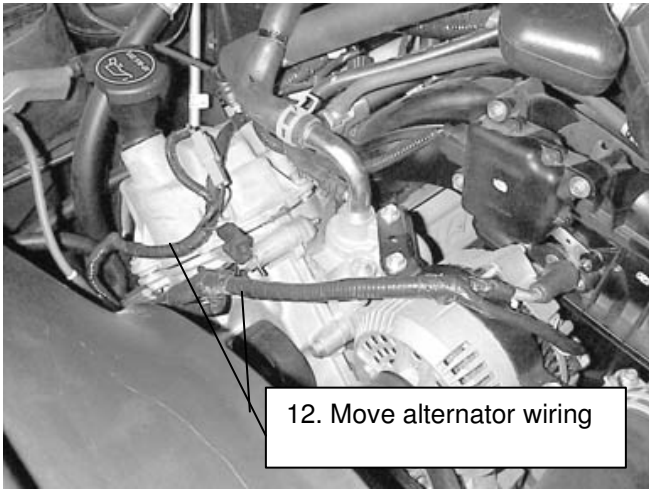

Fig. 3

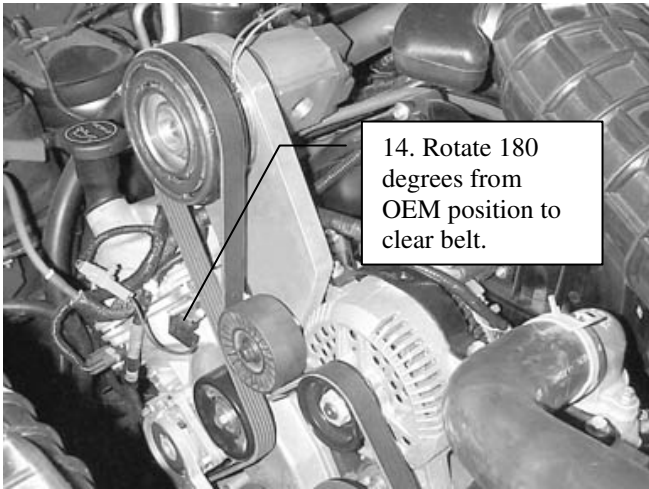

Fig. 4