

Chevrolet/GMC, 6.6L : D, 4500, 5500, 2007+, A Pump, Rear Port

Bolt Packages:

Bracket	711850 (Inc. item 3, 9, 13, 18-21)
Idler	711851 (Inc. item 4, 10, 15)
Crank pulley	None
Tensioner	None

Bracket Assy.	None		
Issue Date	5-7-07	Revision Date	A 1-8-08

Item Part No. Description

1.	711847	Engine bracket	17.	711854	3/8" Hose, 6" long
2.	711848	Base plate	18.	711909	Spacer
3.	711852	M10 x 90 x 1.5 Bolt	19.	110486	M8 x 1.25 x 30 Bolt
4.	711849	Idler bushing, .875" flange width	20.	520098	.50" Hose clamp
5.	710936	Pump plate	21.	110808	3/8-16 x 3/4 Socket head bolt
6.	742052	Idler pulley	22.	OEM	1.75" Hose clamp
7.	*	Pump / Rear port	23.	740359	Belt, Poly Cog 20-1605, 142"
8.	742016	Clutch			
9.	110217	M10 x 70 x 1.5 Bolt			
10.	110526	M10 x 40 x 1.5 Bolt			
11.	OEM	Coolant tube			
12.	OEM	Radiator hose			
13.	110395	3/8-16 x 1 Socket head bolt			
14.	110425	3/8-16 x 1 1/4 Bolt			
15.	110676	3/8 Flat washer			
16.	OEM	Bolt, coolant tube			

FIG. 1
BELT DIAGRAM

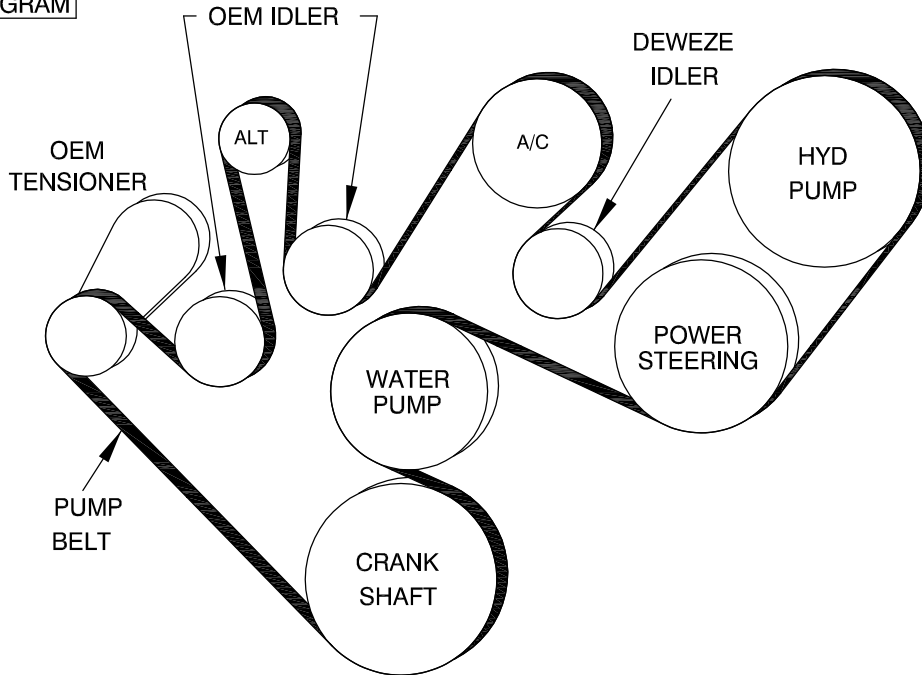

FIG. 2

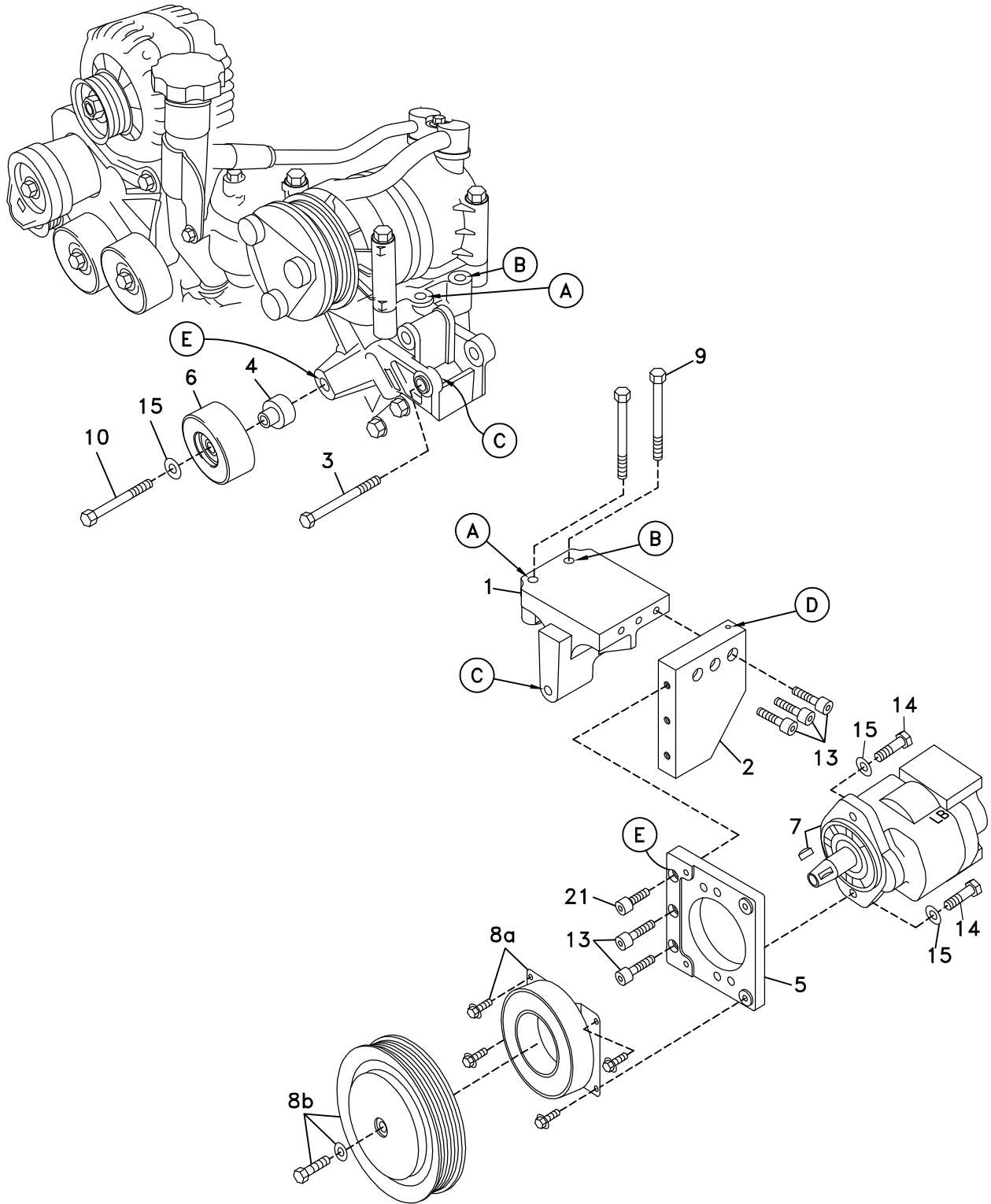

FIG. 3

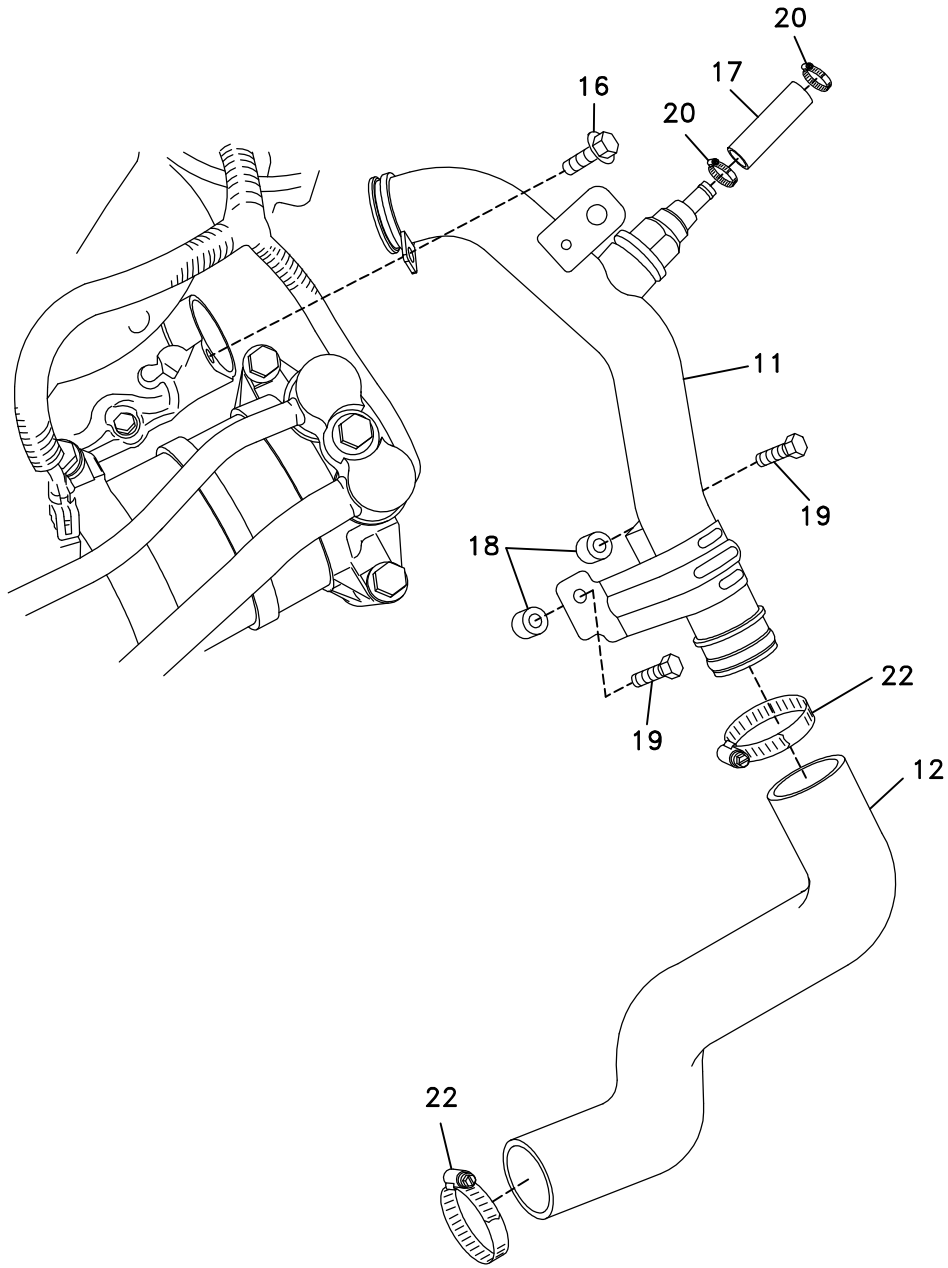
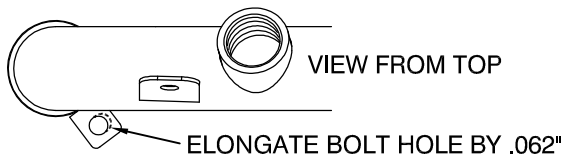

FIG. 4

MODIFY COOLANT TUBE



DewEZE Clutch Pump Kit 700468

Chevy 4500-5500, 6.6L, with A/C, A, Rear Port, 2007+

INSTALLATION INSTRUCTIONS

1. The installation of this kit requires trained decision-making concerning clearances, tying components together, rerouting, or relocating OEM components, etc. It is impossible to describe all of the clearance and vibration points, etc. in the installation instructions. Therefore, the technician must exercise professional judgment to achieve the best quality installation.
2. Disconnect the battery.
3. Remove the OEM belt.
4. Push the idler bushing (4) into the back of the idler pulley (6). Insert the M10 x 40 bolt (10) through a 3/8 flat washer (15), through the idler pulley and bushing and into the boss below the air conditioner at Location E.
5. Bolt the base plate (2) to the engine plate (1) with three 3/8 x 1 socket head bolts (13). Bolt the pump plate (5) to the base plate (1) with one 3/8 x 3/4 socket head bolt (26) and two 3/8 x 1 socket head bolts (13). Torque to 20 ft-lb.
6. Bolt pump (7) onto pump plate (5) with two 3/8 x 1 1/4 bolts (14) and two 3/8 flat washers (15). Torque to 20 ft-lb. Attach coil (8a) with four 1/4 x 1/2 flange bolts supplied with clutch. Torque these to 6 ft-lb. Attach clutch pulley (8b) to pump shaft with 5/16NF x 1 1/4 bolt and heavy washer supplied with clutch. Torque to 14 ft-lb.
7. Insert the two M10 x 70 bolts (9) through the holes in the notched end of the base plate (1) and into the air conditioner mounting bracket at locations A and B. Torque to 25 ft-lb. Thread the M10 x 80 socket head bolt (3) into the hole at Location C and through the bottom lug of the pump bracket. Torque to 25 ft-lb.
8. Remove the OEM radiator hose (28). Unbolt the small L-shaped bracket holding the wiring at the rear of the OEM coolant tube (11). Loosen the OEM hose clamps and remove the 3/8 hose going rearward from the metal tube. Unbolt the three bolts mounting the tube and remove the tube. On the small mounting tab elongate the hole 1/16" toward the tube as shown in Fig. 4. Reinstall the tube with two 1/2" thick spacers (18) under the mounting bracket and attach with two M8 x 30 bolts (19). Install the new 3/8 x 6" long hose (17) using two 1/2" hose clamps (20).
9. Install the belt (23) as shown in the belt diagram (Fig. 1).
10. Connect the battery.
11. Run the engine and check for any clearance or alignment problems. Adjust as needed.